

Astrometry Lost and Regained

From a modest experiment in Copenhagen in 1925 to the Hipparcos and Gaia space missions

Erik Høg

Niels Bohr Institute, Copenhagen University, Denmark

ABSTRACT:

Technological and scientific developments during the past century made a new branch of astronomy flourish, i.e. astrophysics, and resulted in our present deep understanding of the whole Universe. But this brought astrometry almost to extinction because it was considered to be dull and old-fashioned, especially by young astronomers. Astrometry is the much older branch of astronomy, in fact 2000 years of age, which performs accurate measurements of positions, motions and distances of stars and other celestial bodies. Astrometric data are of great scientific and practical importance for investigation of celestial phenomena and also for control of telescopes and satellites and for monitoring of Earth rotation. Our main subject is the development during the 20th century which finally made astrometry flourish as an integral part of astronomy through the success of the Hipparcos astrometric satellite, soon to be followed by the even more powerful Gaia mission.

Synopsis

The renewal of astrometry in the 20th century resulted from work by astronomers who saw the necessity and were able to utilize the newest technology for astrometry, and it is now possible in retrospect to see in detail how this was accomplished. The renewal began with a rather modest experiment on the old meridian circle in Copenhagen in 1925 and culminated with the Hipparcos and Gaia space missions. From 1925 to 1975 the ground was laid by a very small number of researchers who, in fact, acted in a single chain: If any of them had been missing we would not have had any Hipparcos mission, and consequently no Gaia. In 1925 Bengt Strömgren in Copenhagen, Denmark, made experiments with recording of star transits at a meridian circle. He placed a plate with slits in the focal plane with a photocell behind, and recorded the current as a star was moving across. The present author was Strömgren's student 1950 to 1956. Shortly later I went to Hamburg in Germany where I stayed for 15 years. In 1960 I proposed that the recording of star transits should be done with the novel technique of photon counting which was then implemented and used for many years on the Hamburg meridian circle.

In 1967 Pierre Lacroute in Strasbourg, France, proposed to scan the sky with a rotating satellite, recording the star transits with photon counting. Ideas of space astrometry were much studied in

France, but only in France. Especially on French initiative, the European Space Agency began studies in 1975 where I was invited to participate. Swiftly, I made a realistic design of a scanning satellite with many new features. The design was studied by astronomers, ESA engineers and industry, and the Hipparcos astrometric mission was approved in 1980. The satellite was launched in 1989 and completed a three year successful mission. The results were published in 1997 and have since been utilized in many thousand publications. Hipparcos observations were obtained with photoelectric detectors, viz. an image dissector tube and two photomultipliers.

In 1992 I proposed a new astrometric mission where CCD detectors were introduced, resulting in a million times higher observing efficiency than Hipparcos achieved. Such a mission, named Gaia, was approved by ESA in 2000 after deep studies by scientists and engineers, and is due for launch in 2012. Thus, astrometry seemed lost, but has been regained through the application of space techniques after astrometric developments during half a century depending critically on a very few men, and subsequently being implemented by large teams of dedicated scientist and engineers.

Astrometry seemed lost

The revival of astrometry during the last century was possible through photoelectric astrometry applied to space techniques, implemented in the Hipparcos satellite launched by ESA in 1989. The chain of ideas and experiments which led to Hipparcos is traced in the following, for greater detail see Høg (2008 and 2009). Photoelectric techniques were used for astrometry by many scientists in the previous century, but I shall focus on the activities in Copenhagen, Hamburg, Strasbourg and other places in France, leading from a first experiment on the meridian circle in Copenhagen in 1925 up to approval of the Hipparcos mission by ESA in 1980.

The prospects for astrometry looked bleak at the middle of the 20th century. If an astrometrist retired, the vacancy was usually filled with an astrophysicist, and astrophysics was moving towards the exciting new extragalactic astronomy. But the present author did not feel any pressure from this trend when I studied in Copenhagen (1950-56). My teachers at the observatory, Bengt Strömberg and Peter Naur, were both very familiar with astrometry, and it was natural to follow their advice. As a boy, I had read about Tycho Brahe and Ole Rømer, the two Danish heroes in astronomy, who both worked on what is now called astrometry, astronomy of positions.

In fact, important developments were going on also during the middle of the century which eventually allowed me to lead the construction of the Tycho-2 Catalogue with 2.5 million stars. This catalogue has replaced all previous reference catalogues with its positions and proper motions derived from observations with the Hipparcos satellite and 100 years of ground-based observations. Since its release in 2000, Tycho-2 is being used everywhere to guide astronomical

telescopes on the ground and satellites in space, and for astrophysical studies by means of its two-colour photometry.

The term astrometry does not apply to astronomical measurement in general as the word suggests, but only to the measurement of positions on the sky of stars and other celestial objects. The position of a star changes with time due to its proper motion, to the parallax motion created by the motion of the Earth around the Sun, and to the orbital motion in the case of a binary star. The term astrometry came into use to distinguish it from astrophysics, especially after the introduction of stellar spectroscopy 150 years ago and of atomic theory later on, which were used to analyse the spectra. For the two millennia prior to that, astrometry had in fact been the main task of astronomy. Astrometric observational data have been the basis for navigation, time keeping and monitoring of Earth rotation, and they have given us a deep astronomical understanding of stars and their distances and motions, star systems, planetary motions, and the underlying physical laws.

The photoelectric effect was discovered in 1887 by Wilhelm Hallwachs. He saw that a negative charge on a zinc plate was lost when it was illuminated by light of sufficiently high frequency, i.e. high energy. The effect was explained in 1905 by Albert Einstein in terms of atomic theory which earned him the Nobel prize in 1921.

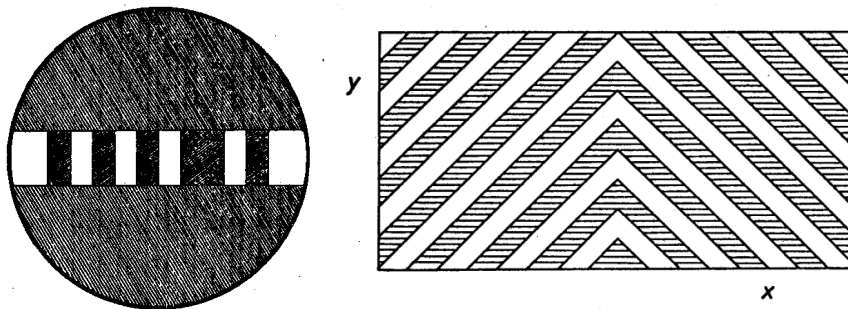

Fig. 1. Two slit systems for photoelectric observation with a meridian circle: Strömgren 1925 and Høg 1960, the latter for two-dimensional measurement. In France it was called “une grille de Høg” in the early 1960s

Photoelectric astrometry in Copenhagen and Hamburg

Bengt Strömgren was introduced to astronomy by his father who was professor and director of the observatory. In 1925, at the age of 17 years, he reported about experiments with photoelectric recording of star transits. In the focal plane of the old meridian circle in Copenhagen he had placed a system of slits parallel to the meridian, Fig.1. Behind the slits a photo cell received the light from the star after it had passed the slits. As the star moved across the slits the variations of light intensity gave corresponding variations in the photo current, and these variations of current were amplified and recorded.

Strömngren, however, found a serious drawback of his initial method: For reasons of statistical noise, it would only allow recording of stars to 6th or 7th magnitude with a medium size meridian circle. In 1933 he therefore proposed a method of integration with a switching mirror and two photocells behind the grid which should allow observation of much fainter stars. But the method posed technical problems and no further experiments have been reported. The present author heard about the two proposals as a student and that bore fruit later on.

In 1940 Bengt Strömngren became director of the observatory located in the centre of Copenhagen. The same year he took the initiative to build a new observatory at a site in Brorfelde 50 km west of Copenhagen. The main instrument, a new meridian circle, was installed in 1953 and I got the task as student to test the stability of the new instrument by photographic observations of a star very close to the North Pole.

Most important for me as a young scientist, was to grow up in an environment where a new meridian circle was the main instrument and where this course for the institute had been defined by an outstanding scientist. Bengt Strömngren gave everybody, not only a youngster as me, confidence about the future line of astronomy. How very different at most other places in the world where astrometry, the astronomy of positions, was being discarded as old science. At such places I would probably have become an astrophysicist, since I certainly did not want to do old stuff.

My studies finished, I became a conscript soldier. Most of the time I had the opportunity to work in a laboratory measuring radioactive decay of dust, collected to follow the nuclear weapon testing of the two superpowers. This involved radioactive counting techniques and my experience with this brand new technique was later applied to photoelectric astrometry.

In 1958 I moved to the Hamburg Observatory where both astrometry and astrophysics were held in high esteem; Otto Heckmann was the powerful director. I wanted to classify stars by objective prism spectra obtained with the big Schmidt telescope and I built a punched card recording system for the spectrum scanner, something new for that time. But in 1960 I returned to astrometry after the excursion in direction of astrophysics and stellar astronomy. I had the idea that Strömngren's method with the switching mirror could be implemented very elegantly by a photon counting technique which I had learnt from the counting of radioactive decay.

A photo multiplier tube should be placed behind a slit system and the photo-electrons be counted in short time intervals, controlled by an accurate clock, and the counts be recorded on punched tape. Later numerical analysis of the counts in a computer would give the transit times across the slits. In principle, the transit time for individual slits could be derived, or the transit time for a

group of slits. The latter method would be less sensitive to noise, and in the course of time both methods have been widely applied.

The slits should be inclined to the stellar motion by 45 degrees in alternating directions, Fig. 1. By such a “fishbone grid” a two-dimensional measurement of the star in the focal plane became possible, corresponding to right ascension and declination.

Astrometry by means of accurate slits and photon counting was subsequently applied on meridian circles, on long-focus telescopes, and ultimately on the first astrometric satellite, Hipparcos. French astronomers became interested in the method, and there were reports from Lille and Besançon in the early 1960s and later followed, Sauzeat (1974) and Creze et al. (1982) where they worked with “une grille de Høg”, as they called the system of inclined slits. The method with the fishbone grid and photon counting was crucial in the proposal for space astrometry by Pierre Lacroute.

Heckmann was immediately interested and the method was implemented on the Hamburg meridian circle for the expedition to Perth, Western Australia. That kept me busy for the next decade and resulted in a catalogue in 1976 with positions of 25,000 stars.

Astrometry with a scanning satellite

Pierre Lacroute, director of the Strasbourg Observatory, presented a project of space astrometry at the General Assembly of the International Astronomical Union (IAU) in Prague in 1967. Lacroute had already presented such a project in a meeting in Bordeaux on 4-6 October 1965, in front of French and Belgian astronomers. This was the first time that such type of astronomy was proposed for a space mission.

The potential advantages were clear, no atmosphere and no gravity, and perhaps thermal stability if that would be technically feasible. I attended the presentation in Prague, but to me and most others the technical problems seemed utterly underestimated. The proposal did not start any activity outside France, but Lacroute’s vision was fortunately shared by other French astronomers, especially by Pierre Bacchus and they worked closely together. Also Jean Kovalevsky supported the project and he has recently given an account of the early years (Kovalevsky 2009). He finally had it converted from being a national project to become European, through ESA.

A study group of astronomers and ESA engineers was set up in 1975 and I joined the group on invitation, in spite of my profound scepticism and lack of interest in space techniques. But the first meeting on 14 October changed my scepticism because the chairman of the meeting urged us not especially to consider the existing proposals, but simply to think about how we could make use of space techniques for our science, astrometry. That made me think freely, in fact converted me to become an enthusiast, and with a number of major changes in the following

weeks I could swiftly transform the satellite to become technically simpler and vastly more effective, see Fig. 2 and Høg (1997).

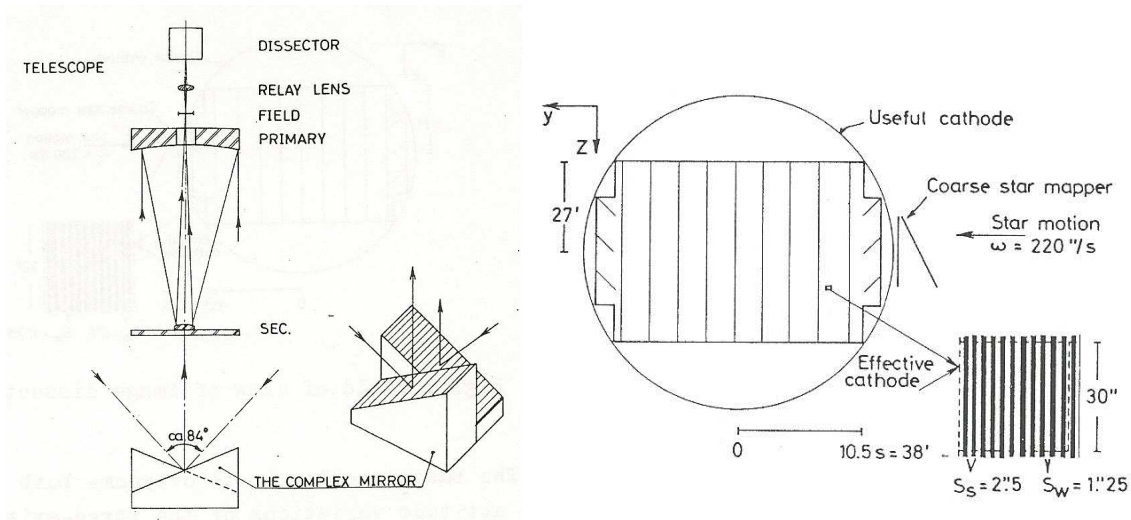

Fig. 2. Hipparcos design by mid 1976. When launched in 1989, the telescope was very different, a folded Schmidt system as shown in Fig. 3, but the slit system and detectors were quite similar

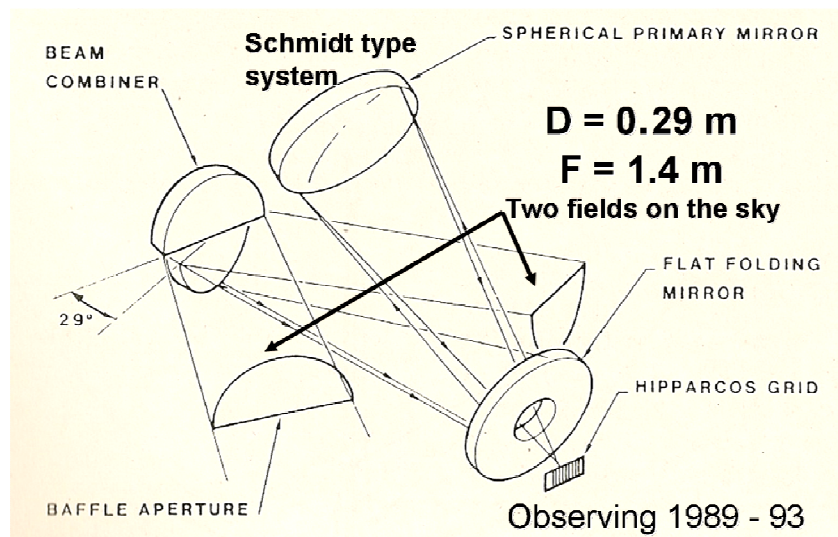

Fig. 3. Hipparcos as launched in 1989: Schmidt system with 29 cm diameter aperture, 1.4 m focal length and two viewing directions, all mirrors silver coated for maximum reflectivity. The satellite rotation makes the stars cross the modulating grid and the Tycho star mapper slits

It is interesting to note that the new design in 1975 was based on technology which had been available also e.g. ten years earlier if somebody would have thought of combining it to an astrometric mission. In particular, the detection was made by an image dissector tube instead of photo multiplier tubes which increased the detection efficiency by a factor of one hundred, and

the image dissector was developed in the 1930s and had since been widely used as electronic television camera.

In 1976 the data reduction was a formidable task: to derive positions, proper motions and parallaxes for 100,000 stars from 10 million angular measures. Fortunately, I was already acquainted with Lennart Lindegren since 1973 when he was a 23 year old student at Lund Observatory. On 22 September I introduced him to Hipparcos and after four weeks he presented the mathematical formulation of the method which was later used during the mission, the “three-step method.” Two weeks later came a report with the first simulations. Without his unfailing genius in all mathematical, computational and optical matters the project would not have been ripe for approval in 1980, and probably never.

By the end of 1979, after studies involving astronomers, ESA engineers and the industry, Hipparcos looked very different from the early ideas laid down by Lacroute. His idea of a satellite scanning the sky with a beam combiner mirror viewing in two directions with one telescope was maintained, but it was yet bolder in its objectives and technically more realistic. As a result, it had also succeeded in generating a substantial scientific following across Europe, backed by an increasingly vocal international community; these sentences are partly quoted from a forthcoming book about the project by Michael Perryman.

During the first months of 1980, decision about the next ESA mission was taken in difficult negotiations where an EXUV project was a very strong competitor. The competition ultimately led ESA to do two things the agency had never done before: firstly to approve two missions at the same time, Hipparcos and the Giotto mission to comet Halley, and secondly to finance the Hipparcos payload out of the science budget. Otherwise ESA always paid spacecraft and launch and the national institutes built and financed their experiments to go on board. Hipparcos was up against great hurdles all the time, but our mission won in the end, thanks to negotiations in which Jean Kovalevsky took part. My own attitude then was that if Hipparcos had lost I was ready to quit the project for lack of faith that the astrophysicists would ever let it through.

In April 1981 the satellite was well into the design phase when significant modifications would normally have been strictly rejected for reasons of risk, and for the increased cost that they would incur. But at that time I realised that the signals from the satellite attitude detectors, i.e. the star mapper slits, contained an enormous quantity of star positions that were not being sent to the ground. I immediately pointed out what was at stake and the modifications to the design were made, including the addition of colour filters and detectors.

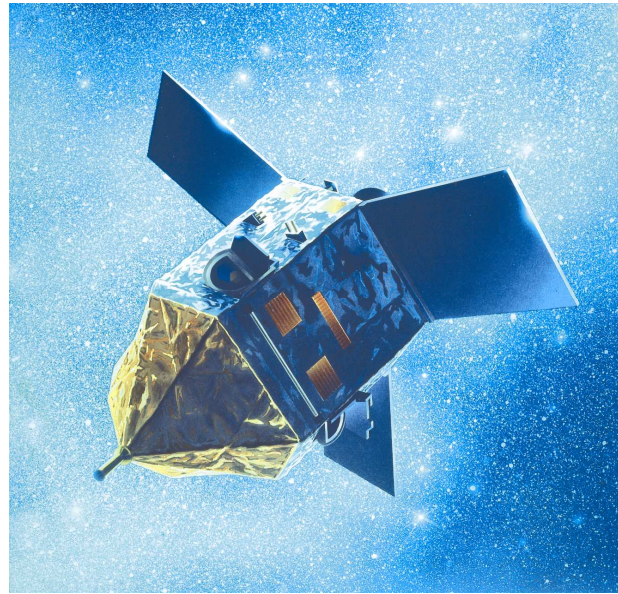

Fig. 4. The Hipparcos satellite launched 1989

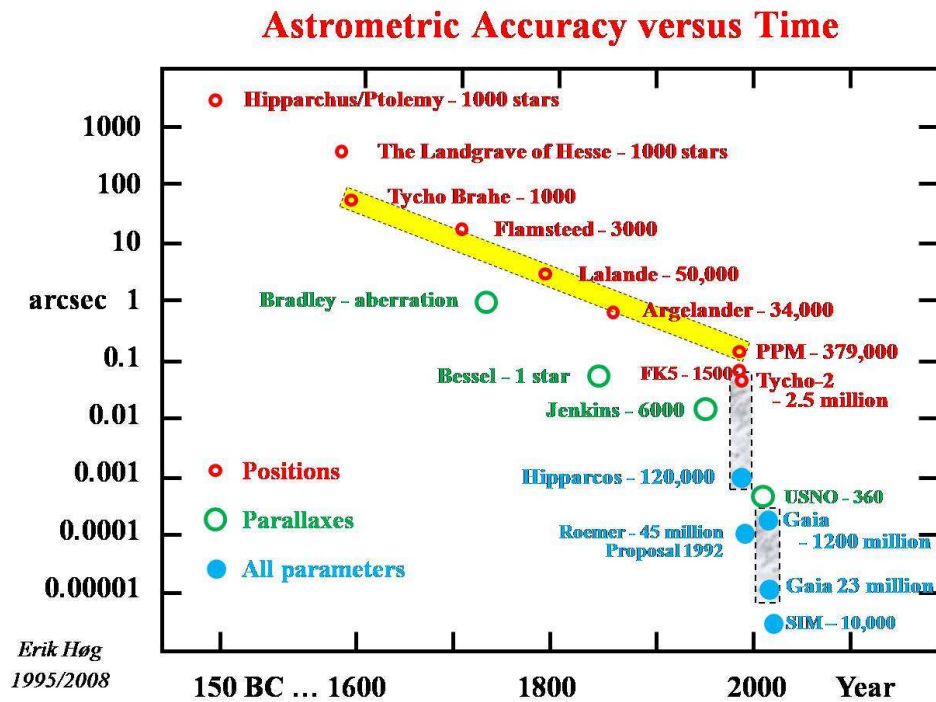

Fig. 5. Astrometric accuracy during the past 2000 years. The accuracy was greatly improved shortly before 1600 by Tycho Brahe. The following 400 years brought even larger but much more gradual improvement before space techniques with the Hipparcos satellite started a new era of astrometry

This “Tycho experiment” as it was called, resulted in the Tycho-2 Catalogue in 2000 with astrometry and two-colour photometry of 2.5 million stars (Høg et al. 2000). Tycho-2 is now the preferred astrometric reference catalogue for stars brighter than 11th magnitude, used to tie the bright 120,000 stars of the Hipparcos system to astrometric observations of fainter stars obtained by ground-based CCD telescopes.

After approval the project gained great momentum and was carried through by large enthusiastic teams (Perryman et al. 1997) working many years guided by the Hipparcos Science Team whose chairman Michael Perryman personifies this phase of the mission more than anyone.

Astrometry regained!

Hipparcos was launched in 1989, Figures 3 and 4, observed for three years, and the results were extensively published in 1997. The two cited papers about the Hipparcos and Tycho Catalogues by Perryman et al. (1997) and Høg et al. (2000) are among the 40 most cited articles in *Astronomy & Astrophysics* out of 50,000 published in 40 years and have therefore been reprinted recently in Volume 500. The Hipparcos Catalogue of 1997 has been superseded by a new reduction of all raw observation data by van Leeuwen (2007) resulting in what may be called Hipparcos-2. The bright stars are much more accurate in this catalogue with the result, e.g., that 30,000 stars obtain distances with less than 10 per cent error, compared to 21,000 in the catalogue from 1997, and to less than 1000 stars before Hipparcos. These facts and the Figure 5 illustrate the revival of astrometry.

Bengt Strömberg appears clearly at the root of my contributions to astrometry, including Hipparcos, and he was directly active before the mission approval in 1980 in order to ensure Danish and Swedish support. It seems from the unbroken chain of actions listed above and detailed in Høg (2008 and 2009) that there would have been no Hipparcos, no space astrometry with a scanning satellite, if any of the four persons Bengt Strömberg, Pierre Lacroute, Jean Kovalevsky or Lennart Lindegren had been absent from the scene before 1980, and I may include myself and Otto Heckmann for his immediate strong support of my ideas.

It appears that the approval by ESA could well have failed, in which case I am sure Hipparcos would never have been realized. This proposition has been countered by a colleague: “*You can never know that, something could have happened.*” But please consider the situation of astrometry at that time. For decades up to 1980 the astrometry community was becoming ever weaker, the older generation retired and very few young scientists entered the field. I myself would have lost the faith that the astrophysicists would ever let such a space mission through, and others would also have left the field of space astrometry.

If someone would have tried a revival of the idea one or two decades later, the available astrometric competence would have been weaker, and where should the faith in space astrometry

have come from? When Hipparcos became a European project in 1975 and the hopes were high for a realization, the competence from many European countries gathered and eventually was able to carry the mission. This could not have been repeated after a rejection of the mission.

But could NASA have realized a Hipparcos-like mission? No, and for two reasons: The American astrometric community had much less resources of competence to draw from than available in Europe, and secondly, as an American colleague said: *“You can convince a US Congressman that it is important to find life on other planets, but not that it is important to measure a hundred thousand stars.”*

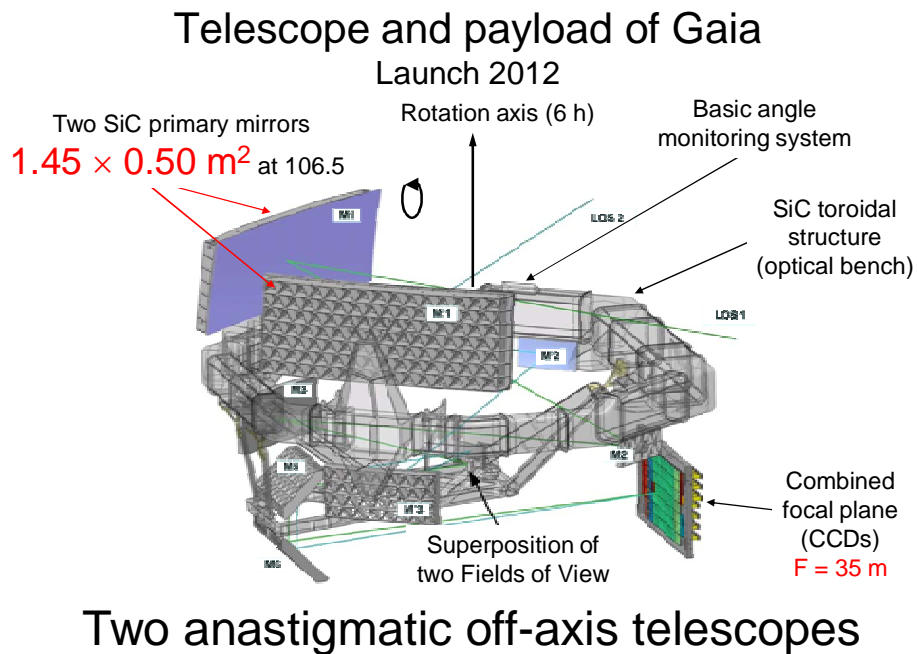

Figure courtesy EADS-Astrium

Fig. 6. The Gaia payload

Thanks to the completion of the Hipparcos mission a strong astrometric community now exists in Europe which has been able to propose and develop the Gaia mission, Figure 6, and which will carry it to a successful completion. Without Hipparcos the faith in the much more difficult CCD technology of Gaia would have been missing. Gaia is a scanning satellite with two directions of view imaged directly on a focal plane, similar to Hipparcos. The star images are however measured not by a photoelectric image dissector tube as in Hipparcos but by a large mosaic of CCDs operated in time-delayed integration (TDI) as proposed in 1992 for the Roemer mission (Høg 1993 and 2007).

Acknowledgements Comments to previous versions of this paper from J. Kovalevsky, H. Pedersen, M. Perryman, C. Turon, and F. van Leeuwen are gratefully acknowledged.

References

Creze M. et al. 1982, *Astro. Astrophys. Suppl. Ser.* 50, 147

Høg E. 1993, *Astrometry and Photometry of 400 Million Stars Brighter than 18 Mag.* Shanghai Sept. 15-19, 1992, *IAU Symp. No.* 156, 37

Høg E. 1997, *From the Hipparcos Mission Definition to Tycho.* In: *ESA SP-402, Hipparcos Venice '97*, B. Battick (ed.), xxvii

Høg, E. 2007, *From the Roemer Mission to Gaia.* At www.astro.ku.dk/~erik/ShanghaiPoster.pdf. *Proceedings of IAU Symposium No. 248 in Shanghai, October 2007*, edited by M.A.C. Perryman & I. Platais

Høg E. 2008, *Astrometry and Optics during the past 2000 Years.* At www.astro.ku.dk/~erik/History.pdf. In total 94 pages

Høg E. 2009, *Astrometry Lost and Regained.* A lecture in, e.g., the Commission for History of Astronomy at the IAU General Assembly in 2009. Power point handouts at www.astro.ku.dk/~erik/AstrometryRegained6.pdf

Høg E., Fabricius C., Makarov V.V., Urban S.E., Corbin T.E., Wycoff G.L., Bastian U., Schwekendiek P. & Wicenec A. 2000, *The Tycho-2 Catalogue of the 2.5 Million Brightest Stars.* *Astron. Astrophys* 355: L27-L30. Reprinted in *A&A* 500

Kovalevsky J. 2009, *The ideas that led ESRO to consider a space astrometry mission.* Report at www.astro.ku.dk/~erik/Kovalevsky2009.pdf

Sauzeat M. 1974, *Astron. Astrophys.* 35, 57

Perryman M.A.C. et al. 1997, *The HIPPARCOS Catalogue.* *Astron. Astrophys.* 323:L49-L52. Reprinted in *A&A* 500

van Leeuwen, F. 2007, *Hipparcos, the New Reduction of the Raw Data.* *Astrophysics and Space Science Library* 350, Springer

van Leeuwen, F. 2007, *Validation of the new Hipparcos Reduction.* *Astron & Astrophys.* 474: 653